

CARSON

Carson Manufacturing Co., Inc.
5451 North Rural Street
Indianapolis, IN 46220
Phone: (888) 577-6877 Fax: (317) 254-2667
www.carsonsirens.com

SA-361-20 REMOTE SIREN AMPLIFIER

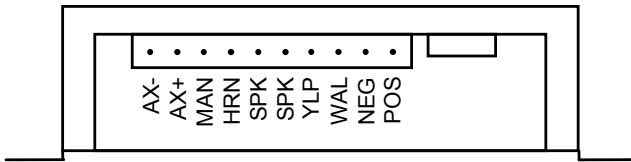
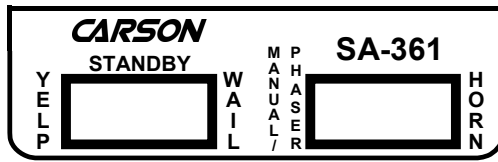

INSTALLATION AND OPERATING INSTRUCTIONS

Carson is a trademark of Carson Manufacturing Company, Inc.

WARNING Sound Hazard - Sound level from siren speaker (>120dBA @ 10 feet) may cause hearing damage. Do not operate siren without adequate hearing protection for you and anyone in immediate vicinity. (Ref. OSHA 1910.95 for occupational noise exposure guidelines)



TABLE OF CONTENTS

GENERAL DESCRIPTION 3

SPECIFICATIONS 3

INSTALLATION 4

 SAFETY PRECAUTIONS 4

 UNPACKING 4

 OPTION SWITCHES 5

 MOUNTING 6

 ELECTRICAL CONNECTIONS 7

OPERATION 9

 POWER ON/OFF 9

 YELP - STANDBY - WAIL SELECTOR SWITCH 9

 MANUAL / PHASER SWITCH 9

 AUXILIARY INPUT FUNCTIONS 9

 Horn Ring Cyclor 2 (HRC2) 9

 WAIL / YELP TOGGLE MODE 9

SERVICE 10

 PROBLEMS 10

 PARTS and ACCESSORIES 11

 RETURNS 12

 WARRANTY 12

NOTICE

Due to continuous product improvements, we must reserve the right to change any specifications and information, contained in this manual at any time without notice.

Carson Manufacturing Co., Inc. makes no warranty of any kind with regard to this manual, including, but not limited to, the implied warranties of merchantability and fitness for a particular purpose.

Carson Manufacturing Co., Inc. shall not be liable for errors contained herein or for incidental or consequential damages in connection with the furnishing, performance, or use of this manual.

See www.carsonsirens.com for latest information.

GENERAL DESCRIPTION

The SA-361 Remote Siren Amplifier is designed for single 100W speaker use. The primary operating modes are Yelp, Wail and Standby, selected by a 3-position rocker switch. Horn Override, push-on/push-off Phaser operation in the Yelp and Wail modes, and Manual siren control in the Standby mode are controlled by a momentary 3-position rocker switch. The unit features instant-on allowing the unit to produce a tone instantly when a switch is activated. The supplied switch panel or other switches may be used for control. A DIP switch on the amplifier provides options to select Two-Tone, disable tones, HRC2 operation, Auxiliary function, and Wail/Yelp toggle mode. The unit utilizes short circuit, high voltage, and reverse polarity protection systems for maximum service life. An output light indicates siren signal output for diagnostics and troubleshooting.

SPECIFICATIONS

Speaker Load	Single 100W 11ohm				
Input Voltage	10 - 16 VDC (negative ground)				
Input Current	8 AMPS (@14 VDC - single 100W speaker)				
Standby Current	0 mA				
Output Power	105 WATTS RMS MAX. (15 VDC - single 100W speaker)				
Siren Frequency	700Hz - 1500Hz (Two-Tone and Horn = 435 & 585Hz)				
Tones / Cycle Rates	Horn	Wail	Yelp	Phaser	Two-Tone
Cycle Rates	109 CPS	13 CPM	190 CPM	15 CPS	60 CPM
High Voltage Protection	16 - 18 VDC will cause siren output to cease, resume at normal voltage				
Short Circuit Current	50 AMPS (supply circuit must be capable of supplying this for 1 second)				
Operating Temp.	-15° F to +140°F				
Controls	3-position rocker selector switch (Yelp, Wail and Standby). 3-position momentary rocker switch (Horn and Manual/Phaser toggle). Positive or Negative Auxiliary input. 8-position DIP switch option selector.				
Connections (10-Pin Connector)	Positive, Negative, (2) Speaker, Auxiliary +, and Auxiliary -. Switch inputs for Wail, Yelp, Horn, Manual/Phaser. Optional Switch inputs for Wail/Yelp, Standby, Horn, Manual/Phaser.				
Size	Control Panel: 3-3/4" Wide, 1-3/4" Deep, 1-1/4" High Amplifier: 5-1/2" Wide, 4-11/16" Deep, 1-13/16" High				
Weight	3 LBS.				



INSTALLATION

Proper installation of the unit is essential for years of safe, reliable operation. Please read all instruction **before** installing the unit. Failure to follow these instructions can cause serious damage to the unit or vehicle and may void warranties.

SAFETY PRECAUTIONS

For the safety of the installer, vehicle operator, passengers and the community please observe the following safety precautions. **Failure to follow all safety precautions and instructions may result in property damage, injury or death.**

Qualifications - The installer must have a firm knowledge of basic electricity, vehicle electrical systems and emergency equipment.

WARNING   **Sound Hazard** - Sound level from siren speaker (>120dBA @ 10 feet) may cause hearing damage. Do not operate siren without adequate hearing protection for you and anyone in immediate vicinity. (Ref. OSHA 1910.95 for occupational noise exposure guidelines)

Mounting - Mount the unit for easy access by the vehicle operator. DO NOT mount in air bag deployment area. Assure clearances before drilling in vehicle.

Wiring - Use wiring capable of handling the current required. Make sure all connections are tight. Route wiring to prevent wear, overheating and interference with air bag deployment. Install and check all wiring before connection to vehicle battery.

Testing - Test all siren functions after installation to assure proper operation. Test vehicle operation to assure no damage to vehicle.

Keep These Instructions - Keep these instructions in the vehicle or other safe place for future reference. Advise the vehicle operator of the location.

UNPACKING

Inspect contents for shipping damage. If found **alert carrier immediately**.

Contact supplier immediately if any items are missing.

Contents of box should include the following items:

Complete Unit

Qty	Item
1	Amplifier (SA-361-20 14)
1	Switch Panel Assembly (ED1773)
1	Connector, 10-P Terminal Block Plug (CP4688-10)
6	Terminal, 3/16" Insulated Female Q.C. (CP4062-K2523)
1	Instruction Manual (CP5054 This Manual)

Amplifier Only

Qty	Item
1	Amplifier (SA-361-20AMP)
1	Connector, 10-P Terminal Block Plug (CP4688-10)
1	Instruction Manual (CP5054 This Manual)

OPTION SWITCHES

An 8-position DIP switch on the remote amplifier may be changed to select various options.

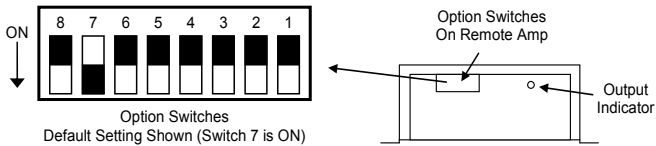

SW-1	SW-2	Auxiliary Input Function with Unit set to Standby
OFF	OFF	(Default) Produces Horn tone while activated.
ON	OFF	Produces Phaser tone while activated.
OFF	ON	Produces Short Manual siren tone (no fall).
ON	ON	Activates Horn Ring Cyclers 2 (HRC2) function.

SW-3 Two-Tone - Turn this switch on to replace Phaser with Two-Tone.

SW-4 Phaser Inhibit - Turn this switch on to disable Phaser tone. Phaser replaced with Yelp.

SW-3 and 4 Siren Tone Disable - All siren tones may be disabled except Horn by turning on both switches. All switches will produce Horn tone.

SW-5 Horn Inhibit - Turn this switch on to disable Horn tone. Horn replaced with Yelp.

SW-6 Wail / Yelp Toggle Mode - The Wail and Yelp remote switch inputs normally activate the Wail and Yelp modes of operation. This mode changes the Wail input to Wail/Yelp toggle while the Yelp input is changed to activate Standby. Turn this switch on to enable this feature. See OPERATION section for further details.

SW-7	SW-8	Remote Switch Input Polarity For Wail, Yelp, Horn, and Manual/Phaser inputs
ON	OFF	(Default) Inputs activated with negative.
OFF	ON	Inputs activated with positive.
OFF	OFF	Inputs will not function.
ON	ON	Inputs will not function. (Do not use this setting, unit will drain battery)

HORN RING CYCLER 2 (HRC2) - Turn on DIP SW-1 and SW-2 to enable this feature. Also connect the auxiliary input to the horn ring or other switch. While the siren is in standby, tap the horn ring to bring the unit out of standby into Wail tone. Repeatedly tapping the horn ring will cycle through Wail, Yelp, and Phaser tones. Tapping the horn ring twice quickly will stop the siren tones and return the unit to standby. Pressing and holding the horn ring will produce Horn tone until released. Then the siren will return to its previous siren tone or standby.

MOUNTING - (Amplifier)

Select a location for the amplifier in an area such as the driver compartment firewall, under a seat, etc. Mounting the amplifier in the engine compartment or in an area directly exposed to weather is **not** recommended. Assure adequate ventilation to prevent overheating. Allow clearance for wiring. Inspect behind mounting area for clearance. Mark the location of the mounting holes to be drilled. Drill 4 holes (up to 1/4" diameter) to mount the amplifier to the vehicle. Install the terminal block plug and make all electrical connections before final mounting. Then mount the amplifier to the vehicle using appropriate hardware (not supplied).

MOUNTING - (Switch Panel)

The switch panel is typically mounted underneath the vehicle dashboard using mounting hardware (not supplied). Mount the panel in a location away from the driver's or passenger's legs. **DO NOT** mount in air bag deployment area.

MOTORCYCLE LOCATION

A common location for the remote amplifier on a motorcycle is in the saddle bags. Make sure **road flares** are kept away from the amplifier in a separate container or compartment. The chemicals in the flares may corrode the amplifier and circuitry.

ELECTRICAL CONNECTIONS - Amplifier

Electrical connections to the amplifier are made using a terminal block plug located on the amplifier. A label on the unit identifies each terminal function. Install the plug on the unit before wiring. If the unit needs service the plug can be easily removed without unwiring. The power supply of the unit must be capable of delivering peak currents up to 50 amps for adequate short circuit protection and reliable operation. The preferred source is directly at the vehicle battery. The amplifier is fused near connector.

Attach leads by stripping 3/8", inserting into connector and clamp by tightening screw. Make sure the screw is tight and the wire can't be pulled out.

Failure to adequately tighten the screw can result in improper operation or burning the connector and wire.

Wire Size and Termination - The diagram shows the minimum wire size used for each connection, along with recommended lead color. If the wire is longer than 10 ft. use the next larger wire size. Use only high quality crimp connectors for installation on the vehicle.

Auxiliary Input Connection (AX+ or AX-) (Optional) - A momentary input typically connected to the horn ring of the vehicle or other switch.

See OPERATION section for auxiliary input functions.

NOTE: Permanent disconnection of the vehicle horn is NOT recommended.

The auxiliary input may be activated with positive (AX+) or negative (AX-) voltage. Input current is less than 1 mA.

ELECTRICAL CONNECTIONS - Switch Panel (Optional)

Electrical connections to the switch panel are made using 3/16" quick connect terminals (supplied loose) and wired to the switch control inputs on the amplifier.

The center terminal of each switch may be connected to positive or negative.

See OPTION SWITCHES section to select proper polarity.

Input current is less than 20 mA.

ELECTRICAL CONNECTIONS - User supplied Switches (Optional)

The switch control inputs (WAL, YLP, MAN, and HRN) may be controlled with other switches.

The "YELP - STANDBY - WAIL" equivalent switch should be a SPDT ON - OFF - ON. The "MAN/PHSR - HORN" equivalent switch should be a momentary SPDT (ON) - OFF - (ON) or two momentary SPST OFF - (ON) switches for each input.

The inputs may be controlled with positive or negative voltage.

See OPTION SWITCHES section to select proper polarity.

Input current is less than 20 mA.

In Wail / Yelp Toggle Mode the WAL and YLP inputs provide a different function. When the WAL input is momentarily activated, the unit will toggle between Wail and Yelp mode. Activating the YLP input will return the unit to Standby mode. The switch used should be a momentary SPDT (ON) - OFF - (ON) or two momentary SPST OFF - (ON) switches for each input.

Be sure to use a switch that **MOMENTARILY** activates the YLP input for Standby mode. If the YLP input is constantly activated the unit consumes power and may drain the vehicle battery.

This mode must be selected. See OPTION SWITCHES section.

See OPERATION section for further details.

ELECTRICAL CONNECTIONS CONTINUED

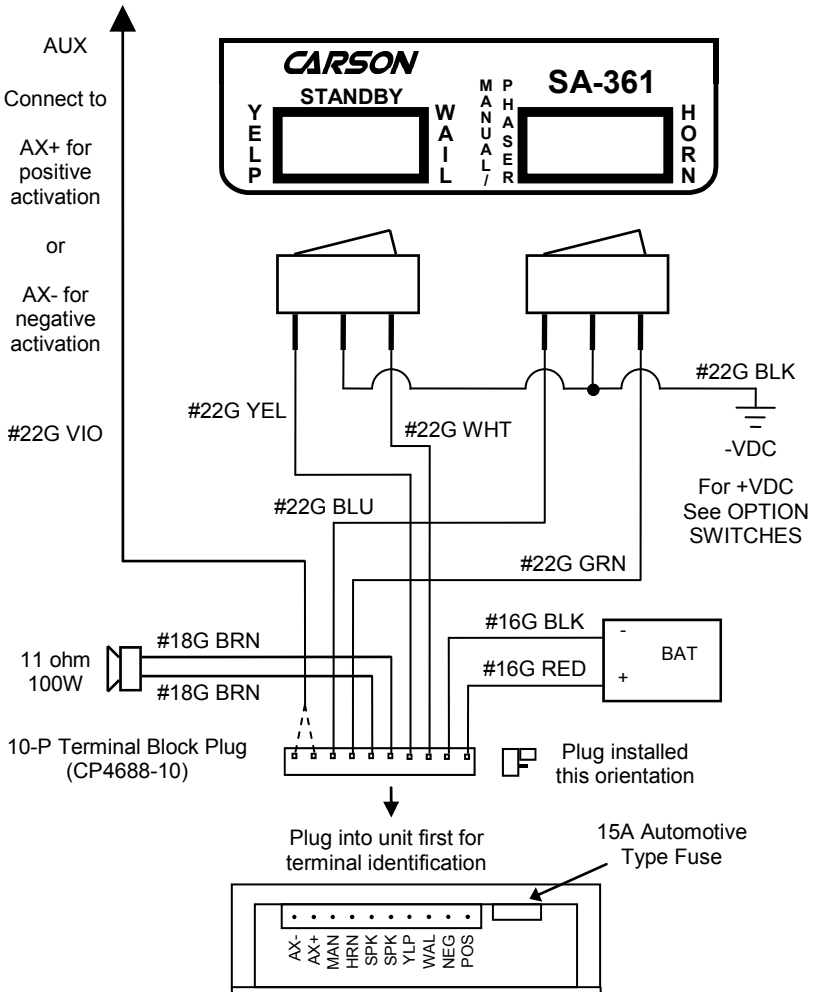
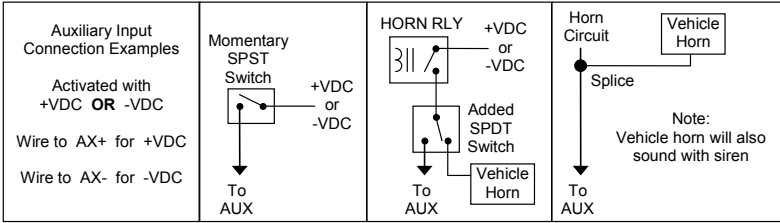

OPERATION

WARNING Sound Hazard - Sound level from siren speaker (>120dBA @ 10 feet) may cause hearing damage. Do not operate siren without adequate hearing protection for you and anyone in immediate vicinity. (Ref. OSHA 1910.95 for occupational noise exposure guidelines)



POWER ON/OFF

The unit is turned on/off automatically (instant on) with the siren or auxiliary input controls.

YELP - STANDBY - WAIL SELECTOR SWITCH

A 3-position rocker selector switch controls the primary operating mode of the siren.

Yelp - A rapidly changing tone used in congested areas.

Wail - A slower changing tone used on highways.

Standby - A silent mode that may be overridden anytime.



MANUAL/PHASER - HORN SWITCH

This momentary rocker switch provides Manual, Phaser toggle, or Horn tones.

Manual - With selector switch in **Standby**, siren tone rises while pressed and falls when released until silenced.

Horn - Overrides all other siren tones when pressed.

Provides a simulated air-horn tone that can be used to supplement the normal vehicle horn. Used at intersections or in low noise areas. Horn tone may be disabled.

See OPTION SWITCHES section.

Phaser - With selector switch in **Wail** or **Yelp**, this tone override is toggled on and off by repeatedly pressing switch. A very rapid changing tone used at intersections and very highly congested areas. May be optionally replaced with **Two-Tone** or disabled. Two-Tone is two alternating frequencies like a European. See OPTION SWITCHES section.



AUXILIARY INPUT FUNCTIONS

The switch or horn ring attached is intended to be momentary.

When the selector switch is in **Wail** or **Yelp**, activating auxiliary will produce the Horn tone.

With selector switch in **Standby**, activating auxiliary will normally produce Horn tone. Different tones are available. See OPTION SWITCHES section.

Horn Ring Cyclor 2 (HRC2) - this feature may also be added by turning on the HRC2 option. HRC2 is only available while the unit is in **Standby**. Tapping the attached horn ring or other switch, will bring the unit out of standby into Wail tone. Repeatedly tapping the horn ring will cycle through Wail, Yelp, and Phaser tones. Tapping the horn ring twice quickly will stop the siren tones and return the unit to standby. Pressing and holding the horn ring will produce Horn tone until released. Then the siren will return to its previous siren tone or standby.

Selector Switch (Mode)	Manual/Phaser Switch	Horn Switch	Auxiliary Input (Horn Ring)
Standby	Manual	Horn	Horn (Default), Short Manual (no fall), Phaser, or HRC2
Wail or Yelp	Phaser Toggle	Horn	Horn

WAIL / YELP TOGGLE MODE

This mode must be activated during installation. See ELECTRICAL CONNECTIONS section. Momentarily pressing the Wail/Yelp switch will bring the unit out of standby into Wail mode. Repeatedly pressing the Wail/Yelp switch toggles between Wail and Yelp modes. Pressing and holding the Wail/Yelp switch will produce Horn tone until released. Momentarily pressing the Standby switch returns the unit to Standby mode. The remaining controls will function as described earlier.

SERVICE

This unit is designed to provide years of reliable service under even the worst conditions. Many times there may appear to be a problem with the unit when the true problem is in the speaker or improper installation. The following chart shows typical symptoms and possible causes.

A blown siren fuse doesn't necessarily mean that the unit is bad. If a speaker or speaker lead is shorted the fuse will blow before the unit is damaged. Disconnect the SPK leads and replace the fuse. If the **OUTPUT** light (located near option switches on amplifier) comes on with Wail switch activated the amplifier is OK. Check the speaker or leads for possible shorting.

PROBLEMS

Symptom	Possible Cause	Check
No power or siren output	Bad speaker Connector loose Amplifier fuse blown Loose connection at power source Wrong polarity on remote switches	Is the OUTPUT light on face coming on in Wail? Is an external fuse or circuit breaker used? Are the negative leads connected to a good ground? Are the Input Polarity option switches set properly?
No siren tones	Bad Speaker High Voltage Protection All siren tones disabled	Is the OUTPUT light on face coming on in Wail? Input voltage must be less than highest rated voltage. Are the option switches set properly?
Distorted siren sound	Speaker assembly loose Intermittent remote switch connection Low vehicle voltage	Is the speaker bell or tip loose? Are the remote switches wired properly? Input voltage must be greater than lowest rated voltage.
Intermittent siren tone	High Voltage Protection Connector loose Bad power connection Circuit breaker in supply connection	Is the vehicle voltage regulator working properly? Is the connector tight on the back of the unit? Is there a loose connection on a power lead? Is a circuit breaker used with at least a 50A rating?
Horn function stuck on or Manual/Phaser stuck on	Horn switch stuck Manual/Phaser switch stuck Switch input improperly connected Switch Input Polarity Option set wrong Aux Input improperly connected	Does the Horn switch return when released? Does the Manual/Phaser switch return when released? Are the correct switch terminals wired? Are the Input Polarity option switches set properly? Is the Aux Input used and wired properly? Is the correct AX+ or AX- polarity input used?
Wrong siren tone	Two-Tone option selected Tones disabled Wail/Yelp Toggle Mode selected Remote switches wired incorrectly	Check option switch settings. Are the correct switch terminals wired?
Some siren tones not working	Tone disabled Remote switches wired incorrectly	Check option switch settings. Are the correct switch terminals wired?

See www.carsonsirens.com for additional information
or contact our Service Department at:
E-mail service@carsonsirens.com or Phone (888) 577-6877

PARTS and ACCESSORIES

The following parts and accessories are available from Carson Manufacturing Company, Inc.:

Part	Description
CP4990-150	Fuse, 15 Amp Mini Automotive
CP4748-2	Switch, Red Rocker ON - OFF - ON (Yelp - Standby - Wail)
CP4751-2	Switch, Momentary Red Rocker Switch, (ON) - OFF - (ON) (Manual/Phaser - Horn)
CP4998	Transistor, output (replace in pairs, 2 required)
Accessory	Description * - standard accessory supplied with complete unit
CP4688-10 *	Connector, 10-pin Terminal Block Plug
CP4062-K2523 *	Terminal, 3/16" insulated female Q.C.
SA-361-20AMP	SA-361-20 Remote Amplifier Only (includes 10-pin connector)
ED1773 *	SA-361 Remote Panel Assembly (includes rocker switches)
CP5054 *	Instruction Manual

See www.carsonsirens.com for additional information
or contact our Service Department at:
E-mail service@carsonsirens.com or Phone (888) 577-6877

RETURN

If you have any questions concerning this or any other Carson product, please contact our **Technical Service Department** at (888) 577-6877. Many issues can be handled over the phone. We can also be reached via e-mail at **service@carsonsirens.com**

If a product must be returned for any reason, please contact our Technical Service Department to obtain a Returned Merchandise Authorization number (RMA#) before you ship the product to Carson. Please write the RMA# clearly on the package near the mailing label. Be sure to provide a return address, contact and phone number, along with a brief description of the problem.

LIMITED WARRANTY

Carson Manufacturing Company, Inc. warrants this new product to be free from defects in material and workmanship, under normal use and service, for a period of five (5) years from the date of delivery to the first user-purchaser.

During this warranty period the obligation of Carson Manufacturing is limited to repairing or replacing, as Carson Manufacturing may elect, any part or parts of such product which after examination by Carson Manufacturing is determined to be defective in material and/or workmanship.

This warranty does not cover labor charges for removal or re-installation of the product. Fuses and lamps are not covered under this warranty.

This warranty does not extend to any unit that has been subjected to abuse, misuse, improper installation or which has not been adequately maintained, nor to units which have problems related to service or modification at any facility other than Carson Mfg.

THERE ARE NO OTHER WARRANTIES, EXPRESSED OR IMPLIED, INCLUDING BUT NOT LIMITED TO, ANY IMPLIED WARRANTIES OF MERCHANTABILITY OR FITNESS FOR A PARTICULAR PURPOSE. IN NO EVENT SHALL CARSON MANUFACTURING COMPANY, INC. BE LIABLE FOR ANY LOSS OF PROFITS OR ANY INDIRECT OR CONSEQUENTIAL DAMAGES ARISING OUT OF ANY SUCH DEFECT IN MATERIALS OR WORKMANSHIP.