

CARSON

Carson Manufacturing Co., Inc.
5451 North Rural Street
Indianapolis, IN 46220
Phone: (888) 577-6877 Fax: (317) 254-2667
www.carsonsirens.com

SC-407 Ver. B

LIGHT CONTROL / SIREN AMPLIFIER

Ver. B has different Auxiliary and Cutout Input Polarity Options

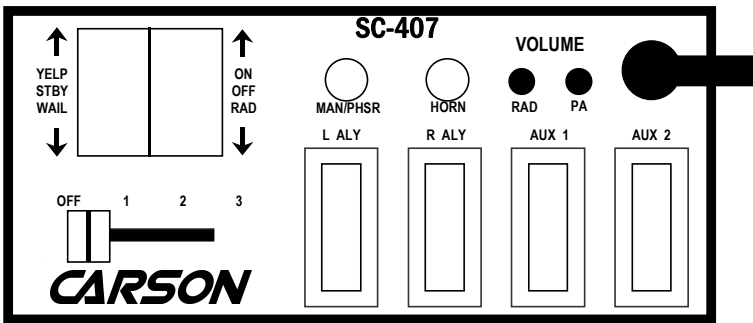

INSTALLATION AND OPERATING INSTRUCTIONS

Carson is a trademark of Carson Manufacturing Company, Inc.

WARNING Sound Hazard - Sound level from siren speaker (>120dBA @ 10 feet) may cause hearing damage. Do not operate siren without adequate hearing protection for you and anyone in immediate vicinity. (Ref. OSHA 1910.95 for occupational noise exposure guidelines)

TABLE OF CONTENTS

GENERAL DESCRIPTION 3

SPECIFICATIONS 3

INSTALLATION 4

 SAFETY PRECAUTIONS 4

 UNPACKING 4

 INSTALLER-SELECTABLE OPTIONS 5

 MOUNTING 6

 ELECTRICAL CONNECTIONS 6

 AMPLIFIER CONNECTIONS 7

 LIGHT CONTROL CONNECTIONS 8

OPERATION 10

 GENERAL 10

 SIREN CONTROLS 10

 Selector Switch 10

 Man/Phsr Switch 10

 Horn Switch 10

 Auxiliary Input (Optional) 10

 Cutout Input (Optional) 11

 Horn Ring Cyclor 2 (HRC2) (Optional) 11

 PA Override 11

 PA Volume Control 11

 Radio Volume Control 11

 LIGHT SYSTEM CONTROLS 12

 Lever Switch 12

 Automatic Siren 12

 Rocker Switches 12

SERVICE 13

 PROBLEMS 13

 PARTS and ACCESSORIES 14

 RETURN 15

 LIMITED WARRANTY 15

NOTICE

Due to continuous product improvements, we must reserve the right to change any specifications and information, contained in this manual at any time without notice.
 Carson Manufacturing Co., Inc. makes no warranty of any kind with regard to this manual, including, but not limited to, the implied warranties of merchantability and fitness for a particular purpose.
 Carson Manufacturing Co., Inc. shall not be liable for errors contained herein or for incidental or consequential damages in connection with the furnishing, performance, or use of this manual.

See www.carsonsirens.com for latest information.

GENERAL DESCRIPTION

The SC-407 Light Control/Siren is a premium unit designed for single or dual 100W speaker use and lighting control. The primary siren operating modes are Yelp, Wail, Standby and Radio. A Noise Canceling PA Override and push-button Horn Override are available in all modes except Radio. A push-button is provided for push-on/push-off Phaser operation in the Yelp and Wail modes, and Manual siren control in the Standby mode. The Phaser function can be optionally replaced by Two-Tone or disabled entirely with program jumpers. Another option allows cycling through Wail, Yelp, and Phaser by pressing the horn ring when the function switch is in the Standby position (Horn Ring Cyclor 2). A latching siren cutout input is provided for connection to a door switch, etc. to disable the siren when exiting the vehicle. Radio and PA volume controls are provided on the front panel. The front panel is backlit with LED's for night visibility. This compact unit utilizes short circuit, high voltage, and reverse polarity protection systems for maximum service life.

The SC-407 provides a 4-position lever switch with LED indicators for primary lighting system control of up to 60 amps total, and four illuminating rocker switches provide additional lighting control with 20 amp per switch rating. The lever switch provides automatic Wail or Yelp siren activation in position 3 (can be disabled). The light controls are directly connected via heavy lead wires to assure high reliability.

SPECIFICATIONS

Siren Section					
Input Voltage	9 - 16 VDC (negative ground)				
Input Current	8 AMPS (@14 VDC - single 100W speaker) 16 AMPS (@14 VDC - dual 100W speakers)				
Standby Current	Less than 300 ma				
Audio Frequency	200Hz - 10 kHz ± 3db				
Audio Distortion	Less than 3% (@1 kHz - single 100W speaker)				
Audio Output	40 watts (@14 VDC - single 100W speaker)				
Audio Input	0.75V RMS MIN. 400 ohms nominal				
Output Power	105 WATTS RMS MAX. (15 VDC - single 100W speaker) 180 WATTS RMS MAX. (15 VDC - dual 100W speakers)				
Siren Frequency	700Hz - 1450Hz (Two-Tone and Horn = 435 & 585Hz)				
Tones / Cycle Rates	Horn	Wail	Yelp	Phaser	Two-Tone
Cycle Rates	109 CPS	15 CPM	210 CPM	15 CPS	60 CPM
High Voltage Prot.	16 - 18 VDC will cause siren output to cease, resume at normal				
Short Circuit Current	50 AMPS (supply circuit must provide for 1 second until fuse ruptures)				
Operating Temp.	-15° F to +140°F				
Controls	3-position siren mode rocker switch (Yelp, Standby and Wail). 3-position power mode rocker switch (On, Off and Radio). Momentary push-button Horn switches. Momentary push-button Manual/Phaser toggle switch. Auxiliary input connection jumper-programmable for positive or negative Horn, Manual/Phaser or Horn Ring Cyclor 2 operation. Cutout input connection jumper-programmable for positive or negative latching cutout operation.				
Connections (10-Pin Conn.)	(2) Positive, (2) Negative, (2) Speaker, (2) Radio, Cutout, Auxiliary				
Light Control Section					
Voltage	9 - 16 VDC (negative ground)				
Controls	4-position lever switch with position 3 siren activation and LED indicators 4 - illuminated on/off rocker switches				
Current (Lever Switch)	30 AMPS per circuit, 60 AMPS total				
Current (Rocker Sw.)	20 AMPS per switch				
Connections (Leads)	Lever Switch - (1) #10 AWG input, (3) #14 AWG outputs Rocker Switches - (1) #14 AWG input and (1) #14 AWG output per switch EXTERNAL FUSING REQUIRED				
General					
Size	6-1/8" Wide, 5-7/8" Deep, 2-7/8" High				
Weight	5-1/2 LBS.				



INSTALLATION

Proper installation of the unit is essential for years of safe, reliable operation. Please read all instruction **before** installing the unit. Failure to follow these instructions can cause serious damage to the unit or vehicle and may void warranties.

SAFETY PRECAUTIONS

For the safety of the installer, vehicle operator, passengers and the community please observe the following safety precautions. **Failure to follow all safety precautions and instructions may result in property damage, injury or death.**

Qualifications - The installer must have a firm knowledge of basic electricity, vehicle electrical systems and emergency equipment.

		WARNING Sound Hazard - Sound level from siren speaker (>120dBA @ 10 feet) may cause hearing damage.
		Do not operate siren without adequate hearing protection for you and anyone in immediate vicinity. (Ref. OSHA 1910.95 for occupational noise exposure guidelines)

Mounting - Mount the unit for easy access by the vehicle operator. DO NOT mount in air bag deployment area. Assure clearances before drilling in vehicle. To prevent internal damage mounting bolts must not enter case more than 1/4".

Wiring - Use wiring capable of handling the current required. Make sure all connections are tight. Route wiring to prevent wear, overheating and interference with air bag deployment. Install and check all wiring before connection to vehicle battery.

Testing - Test all siren functions after installation to assure proper operation. Test vehicle operation to assure no damage to vehicle.

Keep These Instructions - Keep these instructions in the vehicle or other safe place for future reference. Advise the vehicle operator of the location.

UNPACKING

Inspect contents for shipping damage. If found **alert carrier immediately**.

Contact supplier immediately if any components are missing.

Contents of box should include the following items:

Qty	Item
1	Amplifier Unit with attached Microphone (SC-407-10 14)
1	Bracket, 'U' Dash Mount (CP3571)
1	Hardware Kit (ED1558) (Kit contains 2 Bolts, 1 10-P Term Block Plug, and 1 Mic Clip)
1	Instruction Manual (CP4842 This Manual)

INSTALLER-SELECTABLE OPTIONS

Resistor jumpers on the circuit board may be cut to select various options. The cover for the unit must be removed to access the jumpers.

Accessing Option Jumpers - The cover is held in place by a snap-fastener on the back of the unit. Hold the unit with the front case flange on the edge of a hard surface and press hard on the back of the unit. The chassis will slide out the front of the cover.

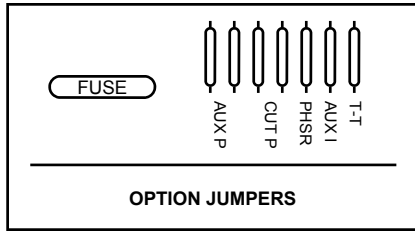

Cutting Option Jumpers - Carefully cut both leads of the option jumper to select the corresponding option.

Auxiliary Input Polarity (AUX_P) - The auxiliary input is normally activated with positive. Cut the two jumper resistors labeled "AUX P".for negative activation.

Cutout Input Polarity (CUT_P) - The cutout input is normally activated with positive. Cut the two jumper resistors labeled "AUX P".for negative activation.

Phaser Disable (PHSR) - The Phaser function may be completely disabled by cutting the jumper resistor labeled "PHSR".

Auxiliary Input Function (AUX_I) - The auxiliary input normally activates the Horn function. Cut the jumper resistor labeled "AUX I".to activate the Man/Phsr function. (Man/Phsr push-button)

Two-Tone (T-T) - Two-Tone can replace Phaser by cutting the jumper resistor labeled "T-T".

Horn Ring Cycler 2 (HRC2) - Cut jumper resistors "AUX_I" and "PHSR" to enable this feature. Also connect the auxiliary input to the horn ring or other switch. While the siren is in standby, tap the horn ring to bring the unit out of standby into Wail tone. Repeatedly tapping the horn ring will cycle through Wail, Yelp, and Phaser tones. Tapping the horn ring twice quickly will stop the siren tones and return the unit to standby. Pressing and holding the horn ring will produce Horn tone until released. Then the siren will return to its previous siren tone or standby.

Horn Disable - The Horn function can be disabled by cutting the trace on the back of the board at the location designated "cut to disable horn".

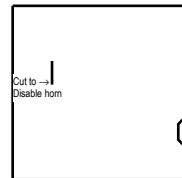

OPTION TRACE CUT

Automatic Siren Disable - To disable automatic siren operation when the lever switch is in position 3 cut and remove the red wire attached to the lever switch relay board.

MOUNTING

The mounting bracket supplied can be installed above or below the unit. Choose a mounting location convenient to the operator and away from any air bag deployment areas. Inspect behind mounting area for clearance. Assure adequate ventilation to prevent overheating. Consider wire routing and access to connections, as well as microphone bracket placement. Install mounting bracket to vehicle using 1/4" hardware (not supplied).

If mounting in a rack or console, make sure that mounting bolts do not enter case more than 1/4".

ELECTRICAL CONNECTIONS

Electrical connections to the unit are made using a terminal block plug and lead wire splices located on the back. Labels on the unit identify each terminal and lead wire function. You should install the plug on the unit before wiring. If the unit needs service the plug can be easily removed without unwiring.

The power supply for the amplifier (10-P plug) must be capable of delivering peak currents up to 50 amps for adequate short circuit protection and reliable operation. The preferred source is directly at the vehicle battery. The amplifier is internally fused.

Attach leads by stripping 3/8", inserting into plug and clamp by tightening screw. Make sure the screw is tight and the wire can't be pulled out.

Failure to adequately tighten the screw can result in improper operation or burning the connector and wire.

Wire Size and Termination - The diagram shows the minimum wire size used for each connection, along with recommended lead color. If the wire is longer than 10 ft. use the next larger wire size. Use only high quality crimp connectors for installation on the vehicle.

Radio Input Connection (Optional) - Connect 1 lead to each terminal of the radio speaker or output connector. The input is isolated and polarity is not important. May need to set Radio Volume on front of unit.

Auxiliary Input Connection (Optional) - The Auxiliary Input allows activation by an external source of either the Horn or Man/Phsr function. Typically connected to the horn ring circuit of the vehicle or other momentary switch. May need to set activation polarity. See INSTALLER-SELECTABLE OPTIONS section for further details.

NOTE: Permanent disconnection of the vehicle horn is NOT recommended.

Cutout Input Connection (Optional) - The Cutout Input turns off any siren tone output when activated, and remains off until a control is activated or changed. . May need to set activation polarity. See INSTALLER-SELECTABLE OPTIONS section for further details.

AMPLIFIER CONNECTIONS

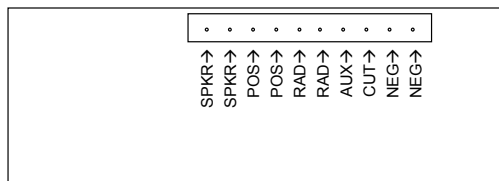
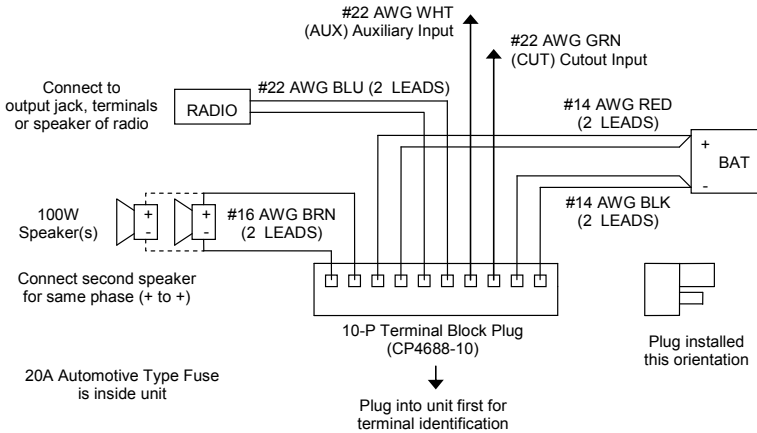
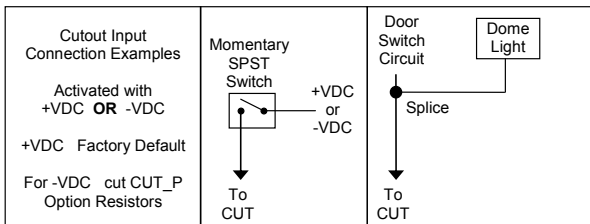
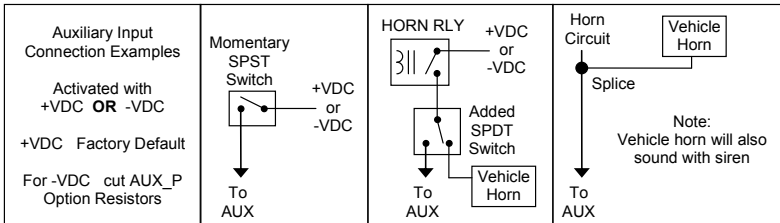

LIGHT CONTROL CONNECTIONS

In addition to these instructions a label located on the bottom of the unit shows the light control switch connections.

Fuses / Breakers

The lighting control circuits of this unit **are not fused**. Automotive fuses or circuit breakers must be connected between the power source and the unit properly rated for the circuit requirements. **Failure to install proper circuit breakers or fuses can result in damage to the unit and/or vehicle.**

Lever Switch Connections

The following diagram shows proper connection of the lever switch leads located at the rear.

Note: Negative (NEG) connection must also be made on 10-Pin plug for proper operation.

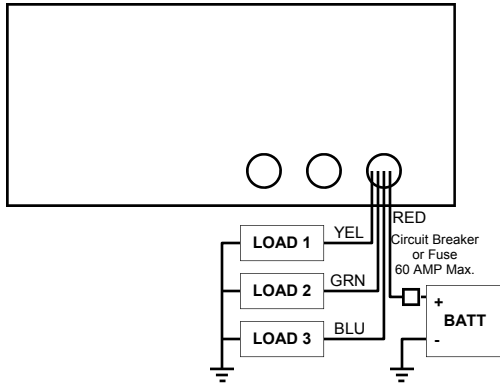

Recommended Wire Size	
Amps	Size
5 - 10	#16
10 - 15	#14
15 - 25	#12
25 - 40	#10
40 - 60	#8
60 - 80	#6
Use next larger size if longer than 10 ft.	

Off 1 2 3	
Lever Position	Turns On
Off	All off
1	Load 1 only
2	Loads 1 and 2
3	Loads 1, 2 and 3

Light Control Rocker Switch Connections

The following diagram shows proper connection of the rocker switch leads located at the rear.

Note: Negative (NEG) connection must also be made on 10-Pin plug for rocker switches to light up.

WARNING: The lighting control circuits of this unit are not fused. Automotive fuses or circuit breakers must be connected between the power source and the unit properly rated for the circuit requirements. Failure to install proper circuit breakers or fuses can result in damage to the unit and/or vehicle.

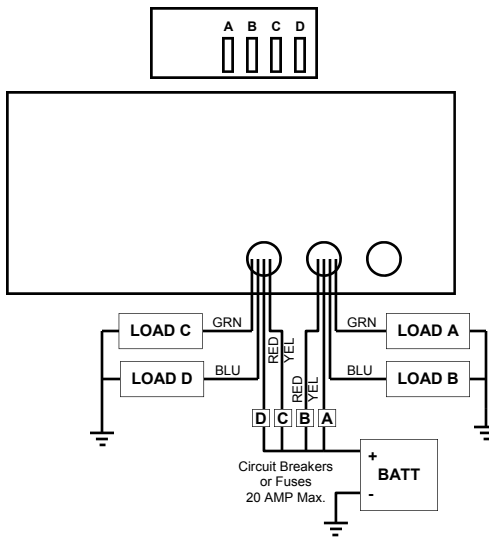

Recommended Wire Size	
Amps	Size
5 - 10	#16
10 - 15	#14
15 - 30	#12
30 - 40	#10
40 - 50	#8
50 - 60	#6
Use next larger size if longer than 10 ft.	

Switch Lead Sets		
Switch	Leads	Hole
A	GRN/YEL	Center
B	BLU/RED	Center
C	GRN/YEL	Left
D	BLU/RED	Left

OPERATION

WARNING  **Sound Hazard** - Sound level from siren speaker (>120dBA @ 10 feet) may cause hearing damage. Do not operate siren without adequate hearing protection for you and anyone in immediate vicinity. (Ref. OSHA 1910.95 for occupational noise exposure guidelines)

GENERAL

This unit is designed for easy operation under the stress associated with high-speed pursuit. Most functions are accessible with one simple motion without repetitive activation of switches or automatic timed switching that can interfere with desired operation.

SIREN CONTROLS

Selector Switch

Two 3-position rocker switches control the primary operating mode of the siren.

On - Applies power to the siren system for operation independent of light control system. It also turns on backlighting for night use.

Off - Turns off power to the siren section.

Radio - Also known as Radio Repeat, this function amplifies a radio speaker input for re-broadcast outside the vehicle. No siren tones or PA operation are available in this position.

Yelp - A rapidly changing tone used in congested areas.

Standby - A silent mode that allows Manual, Horn and Public Address operation.

Wail - A slower changing tone used on highways.



Man/Phsr Switch

With the selector switch in Standby, this momentary push-button switch provides Manual siren tone control, rising when pressed and falling when released. This is used to momentarily alert motorists or in low noise areas. While the selector switch is in Wail or Yelp, this switch provides Phaser tone. This tone is a very rapid changing tone used at intersections and very highly congested areas. Pressing the button once changes to the Phaser tone and pressing again changes the tone back to Yelp or Wail.



Phaser may be optionally replaced with Two-Tone (or Hi - Lo, a common European Tone) or disabled entirely.

See INSTALLER-SELECTABLE OPTIONS section for further details.

Horn Switch

This momentary push-button switch provides a simulated air-horn tone while pressed. This can be used to supplement the normal vehicle horn and is useful at intersections or in low noise areas. This tone will override all other siren tones.

May be optionally disabled. See INSTALLER-SELECTABLE OPTIONS section for further details.

Auxiliary Input (Optional)

During installation an auxiliary input may be connected to the horn ring or other switching device. It provides the same operation as pressing the Horn button or optionally the Man/Phsr button.

See INSTALLER-SELECTABLE OPTIONS section for further details.

Selector Switch	Normal Tone	Man / Phsr Switch	Horn Switch	Auxiliary Input
Standby	Silent	Manual Wail	Mom. Horn	Horn Switch (Man/Phsr Switch or HRC2 option)
Wail	Wail	Phaser Toggle	Mom. Horn	Horn Switch (Man/Phsr Switch option)
Yelp	Yelp	Phaser Toggle	Mom. Horn	Horn Switch (Man/Phsr Switch option)
Radio	Radio	Radio (No Effect)	Radio (No Effect)	Radio (No Effect)

Cutout Input (Optional)

During installation a cutout input may be connected to a door switch. It turns off any siren tone when the door is opened. The siren tone will continue to be cut off even when the door is closed. Changing any siren control switch or input will restore normal function.

Horn Ring Cyclor 2 (HRC2) (Optional)

During installation, the auxiliary input may be connected to the horn ring or other switching device, and the HRC2 option programmed. While the siren is in standby, tap the horn ring to bring the unit out of standby into Wail tone. Repeatedly tapping the horn ring will cycle through Wail, Yelp, and Phaser tones. Tapping the horn ring twice quickly will stop the siren tones and return the unit to standby. Pressing and holding the horn ring will produce Horn tone until released. Then the siren will return to its previous siren tone or standby. Please note that this option disables Phaser selection in the Wail or Yelp selector switch positions.

NOTE: Earlier models with S/N lower than 04190000 have a different version of **HRC**. In this case the siren tones cycle through Standby, Wail, Yelp, and Phaser. The tone is stopped by cycling to Standby.

PA Override

The attached noise-canceling microphone is used for public address operation and overrides any siren tone when the button on the side (PTT) is pressed.

PA Volume Control

With the vehicle parked, set the PA volume to the maximum level with no feedback (squeal).

Radio Volume Control

With the vehicle parked and the radio volume itself set to a normal level, set the siren radio volume to the desired level.

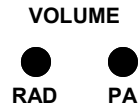

LIGHT SYSTEM CONTROLS

This unit provides large, durable switches for light control function. A 4-position lever switch provides control of primary lighting functions. It also provides automatic activation of the siren system.

Setting the siren control switch to the On position can turn on backlighting of the light control switches.

Lever Switch

The lever switch provides additive control of lighting functions. Position 1 turns on a single lighting function, such as lights pointing to the rear. Position 2 turns on an additional light function, such as lights pointing to the front. Position 3 turns on an additional 3rd lighting function, such as strobes. Position 3 also turns on a siren function (see below). The installer determines actual function.

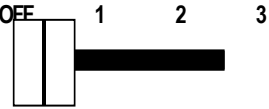

Automatic Siren

Position 3 of the lever switch provides automatic siren control. With both siren control rocker switches set at center position (Stby/Off) the unit will activate the Wail siren tone. With the siren control switches set at Yelp/Off position 3 will activate the Yelp siren tone. The Man/Phsr and Horn switches will operate as if the siren control switches were set at the corresponding positions. PA override is also functional. Automatic siren operation will not work if the right siren control switch is set in the Rad position or the installer has disabled the function.

Rocker Switches

Four rocker switches are provided for various other lighting functions, such as alley lights, deck lights, headlight flashers, etc. The switches light when turned on for night use.

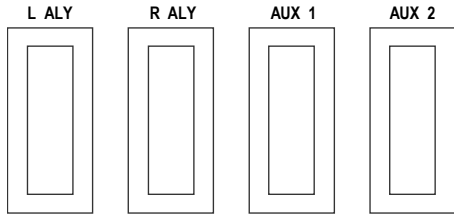

SERVICE

This unit is designed to provide years of reliable service under even the worst conditions. Many times there may appear to be a problem with the unit when the true problem is in the speaker(s) or improper installation. The following chart shows typical symptoms and possible causes. A blown internal fuse doesn't necessarily mean that the unit is bad. If a speaker or speaker lead is shorted the internal fuse will blow before the unit is damaged. Disconnect the SPKR leads and replace the fuse. If the siren emits a sound when in the Yelp position it is OK. Check the speaker (s) or leads for possible shorting.

PROBLEMS

Symptom	Possible Cause	Check
No power or siren output	Power switch not turned on Bad speaker(s) Connector loose Internal fuse blown Loose connection at power source	Does backlighting come on? Do you hear a "pop" when turned on? Is an external fuse or circuit breaker used? Are the negative leads connected to a good ground?
No siren tone - PA works	High Voltage Protection Mic button stuck Cutout activated Cutout Polarity Option set wrong	The input voltage must be less than highest rated voltage. Does mic button release properly? Does the siren work when Cutout input is disconnected? Is the CUT P option properly configured?
No PA	PA volume not set properly Selector in Radio position	Have you tried turning the PA volume control? PA is not available in the Radio position
Distorted siren sound	Speaker assembly loose Intermittent Aux Input connection Low vehicle voltage	Is the speaker bell or tip loose? Is the Aux Input used and wired properly? Input voltage must be greater than lowest rated voltage.
Intermittent siren tone	High Voltage Protection Connector loose Bad power connection Mic button activation Circuit breaker in supply connection	Is the vehicle voltage regulator working properly? Is the connector tight on the back of the unit? Is there a loose connection on a power lead? Is something lying on the microphone? Is a circuit breaker used with at least a 50A rating?
Horn function or Manual or Phaser stuck on	Horn switch stuck Man/Phsr switch stuck Aux Input improperly connected Aux Input Polarity Option set wrong	Does the horn switch return fully when released? Does the Man/Phsr switch return fully when released? Is the Aux Input used and wired properly? Is the AUX P option properly configured?
No Radio	Unit not connected to radio Radio volume too low	Is the radio connected properly to the unit? Can you here the radio in the vehicle? Have you tried turning the RAD volume control?
Wrong siren tone	Two-Tone option installed Aux Input set to wrong function	Is the T-T option jumper cut? Is the AUX I jumper configured properly?
Phaser not working	Phaser disabled	Is the PHSR option jumper cut?
Horn not working	Horn disabled	Is the trace cut that disables the Horn switch?
Automatic Siren not working	Siren Control in RAD position Automatic Siren disabled	Is the siren set to the RAD position? Is the lead cut between the lever switch board and the siren board?
Automatic Siren works in all positions	No power to lever switch board	Do the lever switch indicators light fully? Do the lights work with the lever switch on?
Lever switch not working at all	No power to lever switch board No ground at siren connector	Do the lever switch indicators light? Does the siren work?
Lever switch not working in some positions	Loose output connection on lever switch lead	Does the lever switch indicator work in those positions?
Rocker switch not working	No power to rocker switch Loose rocker switch output lead	Is the corresponding fuse blown? Does the rocker switch light when turned on?

See www.carsonsirens.com for additional information.

or contact our Service Department at:

E-mail service@carsonsirens.com or Phone (888) 577-6877

PARTS and ACCESSORIES

The following parts and accessories are available from Carson Manufacturing Company, Inc.:

Part	Description
CP4968	Actuator, Red (for rocker selector switch)
CP4837	Button, Switch Cap Red (for push-button switch)
CP4684	Control, 1K Vertical w/ Knurled Shaft (PA and Radio Volume)
CP4691-1	Cover (not including chassis)
ATO/ATC 20A	Fuse, 20 Amp Automotive
CP4960	Knob, Lever Switch, Black
CP4844	Label, SC-407 Front Panel
CP4750	Microphone, Noise Canceling w/Connector
SR-15-1	Microphone Strain Relief
CP4701	Relay, 40A SPST light control
CP4699	Switch, Lever
CP4685	Switch, Momentary Push Button (Horn and Man/Phsr)
CP4695	Switch, Rocker Selector, YELP-STBY-WAIL or ON-OFF-RAD (not including actuator)
CP4696	Switch, Rocker, Aux light control
CP4119	Transistor, output (2 required)
Accessory	Description * - standard accessory supplied with unit
CP3633 *	Bracket, Microphone Clip with mounting screws
CP3571 *	Bracket, 'U' Dash Mount
CP3966 *	Bolts, 'U' Mounting Bracket (typically 2 ea required)
ED1756	Cable, 10-P Lead Assembly 8FT (made w/ CP4688-10 Conn)
CP4688-10 *	Connector, 10-P Terminal Block Plug
ED1558 *	Hardware Kit (2 Bolts, CP3633 Mic Clip, CP4688-10 Connector)
CP4842 *	Manual, SC-407-10 Instruction

See www.carsonsirens.com for additional information.

or contact our Service Department at:

E-mail service@carsonsirens.com or Phone (888) 577-6877

RETURN

If you have any questions concerning this or any other Carson product, please contact our **Technical Service Department** at (888) 577-6877. Many issues can be handled over the phone. We can also be reached via e-mail at **service@carsonsirens.com**

If a product must be returned for any reason, please contact our Technical Service Department to obtain a Returned Merchandise Authorization number (RMA#) before you ship the product to Carson. Please write the RMA# clearly on the package near the mailing label. Be sure to provide a return address, contact and phone number, along with a brief description of the problem.

LIMITED WARRANTY

Carson Manufacturing Company, Inc. warrants this new product to be free from defects in material and workmanship, under normal use and service, for a period of five (5) years from the date of delivery to the first user-purchaser.

During this warranty period the obligation of Carson Manufacturing is limited to repairing or replacing, as Carson Manufacturing may elect, any part or parts of such product which after examination by Carson Manufacturing is determined to be defective in material and/or workmanship.

This warranty does not cover labor charges for removal or re-installation of the product. Fuses and lamps are not covered under this warranty.

This warranty does not extend to any unit that has been subjected to abuse, misuse, improper installation or which has not been adequately maintained, nor to units which have problems related to service or modification at any facility other than the manufacturer.

THERE ARE NO OTHER WARRANTIES, EXPRESSED OR IMPLIED, INCLUDING BUT NOT LIMITED TO, ANY IMPLIED WARRANTIES OF MERCHANTABILITY OR FITNESS FOR A PARTICULAR PURPOSE. IN NO EVENT SHALL CARSON MANUFACTURING COMPANY, INC. BE LIABLE FOR ANY LOSS OF PROFITS OR ANY INDIRECT OR CONSEQUENTIAL DAMAGES ARISING OUT OF ANY SUCH DEFECT IN MATERIALS OR WORKMANSHIP.

BLANK PAGE